

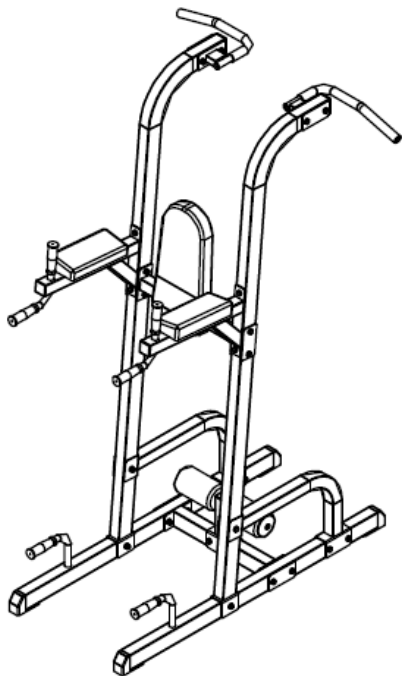

# OWNER'S MANUAL

*PFX – 215 Power Tower*



www.progressionfitness.ca  
info@progressionfitness.ca  
1-306-978-1999

## IMPORTANT SAFETY INFORMATION



Be sure to read the entire manual before assembly and operation. Also, please note the following safety precautions:

- Before using the unit or starting any exercise program, consult your physician. This is especially important for anyone over the age of 65, persons with pre-existing health problems or women that are pregnant.
- Keep children and pets away from this equipment at all times.
- This unit should only be used on a level surface and is intended for indoor use only. We recommend placing an equipment mat under the unit to protect the floor or carpet.
- Do not use until the machine has been fully assembled and inspected for correct performance in accordance with the manual.
- Always wear proper clothing and walking/running shoes when exercising. Do not wear loose fitting clothing that could get caught in the equipment.
- Always examine unit before use to ensure all parts are in working order.
- Progression assumes no responsibility for equipment failure if unauthorized equipment modifications are made.
- Progression assumes no responsibility for personal injury or property damage sustained by or through the use of this product.

## PARTS

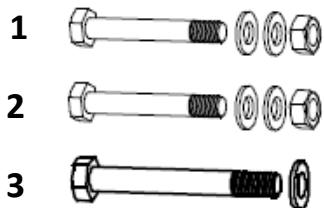

Item	Qty	Description
1	22	Bolt (75mm x 10mm), nut, washer
2	4	Bolt (90mm x 10mm), nut, washer
3	6	Bolt (70mm x 8mm), nut, washer

2

## ASSEMBLY

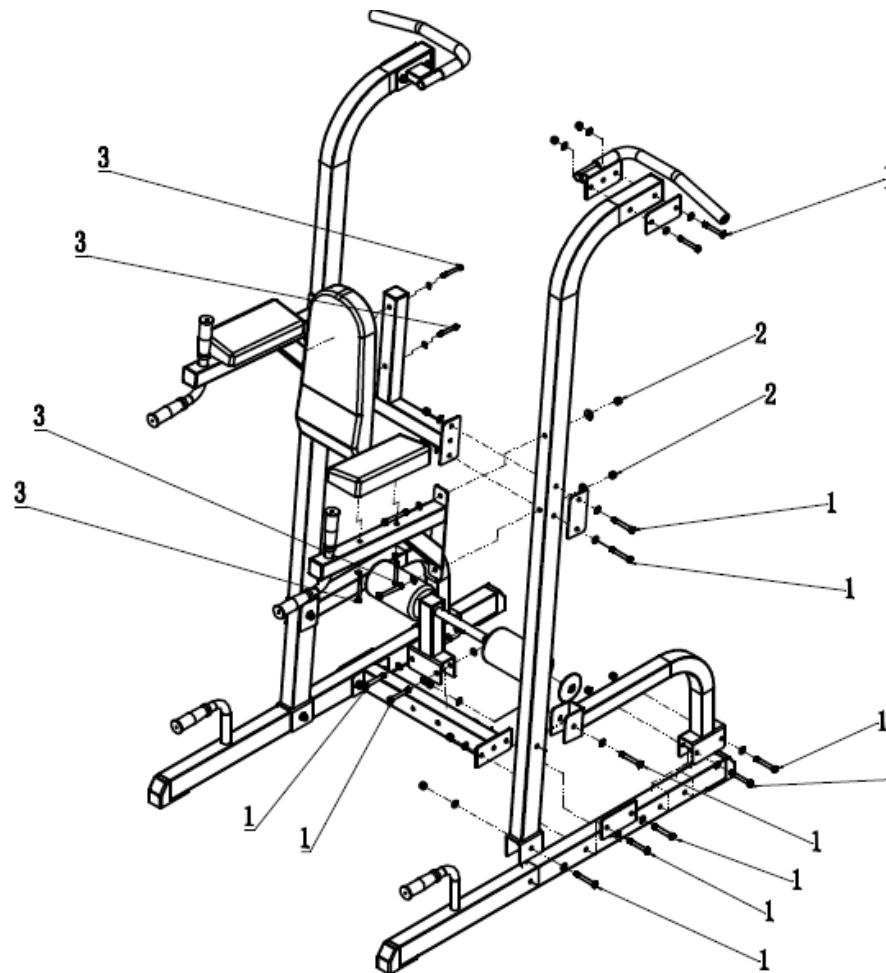

3